

**SUPPLEMENT TO
SPECIFICATIONS FOR
ELECTRICAL INSTALLATIONS**

**OUTDOOR PADMOUNTED
OR VAULT ENCLOSED
THREE PHASE TRANSFORMER**

ELECTRIC SYSTEM BULLETIN No. 754/759

October 2007

(Supersedes issue dated December 2004.)

nationalgrid

TABLE OF CONTENTS

<u>Section</u>	<u>Page</u>
1.0 INTRODUCTION.....	4
1.1 PURPOSE.....	4
1.2 SCOPE.....	4
1.2.1 Provisions.....	4
1.2.2 Additional Customer Provisions.....	5
1.3 CODES AND STANDARDS.....	5
1.4 COMPLIANCE.....	5
1.4.1 Preliminary Design.....	5
1.4.2 Construction Design.....	6
2.0 DEFINITIONS	6
3.0 GENERAL.....	6
3.1 SERVICE VOLTAGE AND MAXIMUM TRANSFORMER SIZE:.....	6
4.0 SERVICE CONNECTIONS	7
4.1 HANDHOLES:.....	7
4.2 MANHOLES:.....	7
4.3 PRIMARY RISER POLE:.....	8
4.4 CUSTOMER'S SECONDARY CONDUIT AND CABLE SYSTEM.....	8
4.4.1 Padmounted Transformer.....	8
4.4.2 Vault Transformer – Utilizing Single Phase Transformers.....	8
4.4.3 Terminations for padmount and single phase transformers.....	9
5.0 TRANSFORMER INSTALLATIONS ON CUSTOMER PREMISES.....	9
5.1 PADMOUNT TRANSFORMER LOCATION.....	9
5.2 PADMOUNT TRANSFORMER FOUNDATION.....	11
5.3 VAULT TRANSFORMER LOCATION, DESIGN AND CONSTRUCTION.....	11
5.3.1 General.....	11
5.3.2 Vault Design and Location.....	12
5.3.3 Vault Construction.....	12
5.3.4 Vault Maintenance.....	14
5.4 SERVICE OPERATING PROCEDURES.....	14
6.0 GROUNDING.....	15
6.1 PADMOUNTED GROUND GRID INSTALLATION.....	15
6.2 VAULT GROUND GRID INSTALLATION.....	15
6.3 GROUND GRID RESISTANCE FOR INSTALLATIONS SUPPLIED FROM DELTA 2.4kV, 4.8kV, 12kV AND ALL 23kV AND 34.5kV SYSTEMS.....	15
6.4 GROUND GRID RESISTANCE FOR INSTALLATIONS SUPPLIED FROM WYE 5kV CLASS AND 15kV CLASS SYSTEMS.....	16
6.5 GROUND GRID INTEGRITY.....	16
7.0 CUSTOMER'S SERVICE EQUIPMENT AND COMPANY METERING.....	16
8.0 PRE-ENERGIZATION REQUIREMENTS	16

TABLE OF CONTENTS (cont'd)

List of Figures

FIGURE 1	Service Installation Diagram – Three Phase Padmounted Transformer
FIGURE 2	Three Phase Padmounted Transformer Required Clearances
FIGURE 3	Grounding Plan - Three-Phase Padmounted Transformer
FIGURE 4	Oil Containment Curb (If Required)
FIGURE 5	Typical Transformer Concrete Pad Dimensions
FIGURE 6	Reinforced Concrete Flat Pad Three-Phase, Padmounted Transformers (Typical Conduit and Foundation Reinforcing Schedule)
FIGURE 7	Typical Above Grade Transformer Vault Customer's Three Phase Service Less Than 600 Volts
FIGURE 8	Typical Above Grade Transformer Vault With Padmounted Transformer Customer's Three Phase Service Less Than 600 Volts
FIGURE 9	Secondary Connections to Padmounted Transformers
FIGURE 10	Typical Primary Cable Handhole Construction
FIGURE 11	Typical Manhole Requirements
FIGURE 12	Typical Primary Riser Pole Detail
FIGURE 13	Typical Trench Details
FIGURE 14	Transformer Installation Checklists

1.0 INTRODUCTION

1.1 Purpose

This Supplement to Electric System Bulletin (ESB) #750 provides specific guidance for Customers whose service point is the secondary side of a Company owned transformer located on Customer owned or controlled property.

This supplement applies where the Company's underground service lateral cable taps a primary distribution or sub-transmission supply facility (that can be either overhead or underground in nature) to feed a Company owned outdoor three phase pad-mounted transformer, or transformer(s) located within a vault. It does not apply in a network area, or in URD / UCD areas.

These requirements are to ensure that the electric facilities will render satisfactory service to the Customer, and will not interfere with the electric supply to others served by the Company's system.

It is important that the Customer and their engineer or contractor obtain and refer to the Specifications for Electrical Installations book (ESB #750) in conjunction with this supplement for these installations.

Installations requiring dual supplies, switching and protection at the transformer, dual primary voltage transformer, or multiple transformers shall be referred to the Company's Engineering Department for specific recommendations and approval.

In response to the Customer's written proposal, the Company will make the final determination as to the size, type, and location of the transformer used to provide service under this bulletin.

1.2 Scope

These requirements concern only those points in which the Customer, their Consulting Engineer, Electrical Contractor, Equipment Manufacturer, and the Company have a mutual interest. This bulletin does not cover the Customer's complete electrical installation design.

1.2.1 Provisions

The installation provisions and costs shall be in accordance with the Company's filed tariffs in the applicable State.

State	Company furnishes, installs, owns and provides maintenance for:	Customer furnishes, installs, owns and provides maintenance for:
MA & RI	<ul style="list-style-type: none"> • an outdoor padmounted transformer • primary cable 	<ul style="list-style-type: none"> • property on which to construct the transformer foundation • transformer pad foundation • ground grid • primary cable trench • outdoor padmounted transformer foundation excavation • where required, the primary conduit system* [it is recommended that spare conduit be installed] • backfill all trenching and excavations after primary cable installation • bollards, if required by the Company
NH	<ul style="list-style-type: none"> • an outdoor padmounted 	<ul style="list-style-type: none"> • property on which to construct the transformer

State	Company furnishes, installs, owns and provides maintenance for:	Customer furnishes, installs, owns and provides maintenance for:
	transformer	foundation <ul style="list-style-type: none"> • primary cable trench • primary cable • outdoor padmounted transformer foundation excavation • transformer pad foundation • ground grid • where required, the primary conduit system [it is recommended that spare conduit be installed] • backfill all trenching and excavations after primary cable installation • bollards, if required by the Company
NY	<ul style="list-style-type: none"> • an outdoor padmounted transformer • primary cable and terminations 	<ul style="list-style-type: none"> • property on which to construct the transformer foundation • primary cable trench • outdoor padmounted transformer foundation excavation • transformer pad foundation • ground grid • where required, the primary conduit system [it is recommended that spare conduit be installed] • backfill all trenching and excavations after primary cable installation • bollards, if required by the Company

* Ownership transfer to Company after initial installation for operation and maintenance.

1.2.2 Additional Customer Provisions

The Customer shall furnish, install, own, and maintain the complete low voltage service connection from the transformer low voltage terminals, including conduit, cables, compression connectors, etc.

1.3 Codes and Standards

The Customer's electric service equipment and its installation shall conform to the requirements of the latest edition of the National Electrical Code (NEC), American National Standards Institute (ANSI), Insulated Cable Engineers Association (ICEA), National Electrical Manufacturer's Association (NEMA), National Fire Protection Association (NFPA), all local ordinances, state and local building codes and Company requirements and specifications.

The Customer should consult their insurance carrier for any special safeguards which the carrier may require for the transformer and switchgear locations.

1.4 Compliance

1.4.1 Preliminary Design

Prior to meeting with the Company, the Customer shall provide three (3) copies of an electrical single-line diagram and a fully dimensioned plot plan indicating property lines, building outlines and detail of the preferred location for the electrical service equipment, transformer pad or vault, as well as the location of other buried facilities.

For a specific installation it is essential the Company meet with the Customer or their representative to mutually establish the arrangement and location of the proposed facilities.

As a result of this meeting, the Company will confirm the delivery voltage, specify the transformer size and type based on the amount of capacity the Customer is currently requesting. In addition the Company will provide the short circuit interrupting duty that the Customer's equipment shall be capable of interrupting based on Section 9 in ESB 750. The Customer is responsible to ensure their service equipment will be satisfactory for the supply characteristics in accordance with the NEC and sufficient for their future maximum demand.

The information the Customers or their contractor furnishes the Company in regard to the Customer's proposed electrical installation shall be in **writing**.

If significant changes are made to the design or scheduling of the installation by the Customer, initial information furnished by the Company shall be subject to review and possible modification.

1.4.2 Construction Design

After the initial meeting, the Company will designate the pole, manhole, or switchgear from which the primary cable will be extended including the route of the primary cable and locations of handholes and manholes.

The Company's Business Services or Distribution Design Department will advise the Customer concerning any contribution required in accordance with the Company's filed tariff.

THE CUSTOMER SHALL SUBMIT THEIR FINAL PLANS TO THE COMPANY BEFORE AWARDING CONTRACTS, ORDERING EQUIPMENT OR STARTING WORK to ensure that the proposed design for the electric service installation conforms to Company requirements. Three (3) copies of the following information shall be submitted to the Company for its acceptance:

1. Architectural drawings and specifications relating to the electric service equipment and transformer pad location. Design drawings pertaining to a vault installation shall be uniformly prepared and sealed by the Customer's design professional.
2. Manufacturer's proposed specifications for the electrical service equipment.
3. Manufacturer's approval assembly drawings relating to the physical arrangement of the electrical service equipment including installation details for metering transformers.
4. Electrical single-line diagram illustrating the service connection up to the main service equipment, metering, and any standby generation including transfer equipment.

2.0 DEFINITIONS

Note: Definitions as used in this specification are provided in the "Specifications for Electrical Installations" book (ESB#750).

3.0 GENERAL

3.1 Service Voltage and Maximum Transformer Size:

<u>Wires</u>	<u>Delivery Voltage</u>	<u>Transformer kVA Limit</u>		
		<u>Outdoor Padmount</u>	<u>Vault (3- 1 ph. transf.)</u>	<u>Vault (padmount)</u>
4	208 wye/120	1000	1000	1000
4	480 wye/277	2500	1500	2500

4.0 SERVICE CONNECTIONS

4.1 Handholes:

- One or more masonry, or polymer concrete, handholes may be required to facilitate cable pulling or conduit drainage.
- Where splicing is necessary, handholes may be permitted for cables less than #4/0AWG.
- The minimum size of a handhole shall be 2-1/2 feet wide x 5 feet long x 3 feet deep, inside dimensions with a full length, two section split cover. Refer to Figure 10 for typical handhole construction.
- The design of the handhole shall be approved by the Company.
- The top of the handhole cover shall be at finished grade.
- All handholes, including covers, shall be capable of withstanding H-20 loading; however, these are not meant for installation in streets and roadways.
- A pulling eye shall be installed on the short width wall and shall be 1-inch diameter eye bolt. The pulling eye and wall shall be capable of 1,500 pounds pulling strength.
- The handhole floor shall be on a flat, #2 crushed stone base 4 inches thick.
- Conduits shall enter the handhole directly opposite each other on the smaller end walls.
- Conduit bells shall be installed on each conduit.
- The centerline of the conduit in the handhole shall be approximately 6 inches from the 5 foot wall and 15 inches above the floor.
- If metallic conduit is used, a #2 CU ground grid shall be installed to allow for the bonding of the conduit. Conduit shall be bonded together with a #4 Cu (solid) to the ground grid.
- Where splicing is necessary for one set of #4/0AWG cables, a heavy duty handhole may be used per Figure 10. For multiple sets of #4/0AWG cables, or cables larger than #4/0AWG a manhole shall be used.

4.2 Manholes:

- One or more masonry or concrete manholes may be required to facilitate cable pulling or conduit drainage.
- The design of the manhole shall be approved by the Company; refer to Figure 11 for specifications.
- All manholes shall have a 26-inch manhole cover with a 36-inch minimum cast iron frame, designed for AASHO-HS20-44 direct wheel loading and 26-inch to 36-inch manhole ring as indicated in Figure 11.
- The top of the manhole cover shall be at finished grade.
- All manholes, including covers, shall be capable of withstanding AASHO-HS20-44 direct wheel loading.
- A 4/0 AWG, 19 strand soft drawn ground grid shall be installed in the manhole.
- If metallic conduit is used, conduit shall be bonded together with a #4 Cu (solid) to the ground grid

4.3 Primary Riser Pole:

The Customer shall install a rigid galvanized steel conduit and a rigid galvanized steel sweep on the Company's primary cable riser pole. For riser conduit installation details, see Figure 12 of this bulletin and refer to Section 4.3.2 and Table 5 "Primary Conduit Sizes" of ESB 750.

4.4 Customer's Secondary Conduit and Cable System

4.4.1 Padmounted Transformer

- Customer's conduits shall be terminated at the equipment pad at the locations shown in Figure 6.
- The Company's transformer will be equipped with bushings that accept NEMA standard two-hole spade terminals mounted in the secondary compartment.
- Size and number of customer's secondary cables (service entrance conductors) shall be in accordance with the NEC and shall be approved by the Authority Having Jurisdiction (AHJ).
- The Customer-owned secondary conductors shall be insulated, stranded cable up to the maximum number listed below (number of conductors/phase and neutral):

Transformer 75°C Spade Terminal	Transformer Application		Maximum Secondary Conductor Sets and Size
	kVA Rating	L.V. Rating	
4 Hole Spades	75 – 300	208Y/120	6 sets 750 kcmil
	75 – 500	480Y/277	
6 Hole Spades	500	208Y/120	8 sets 750 kcmil
	750 – 1500	480Y/277	
10 Hole Spades	750 – 1000	208Y/120	10 sets 600 kcmil or 8 sets of 750 kcmil
	2000 – 2500	480Y/277	

Details of the Company's transformer spade terminals are shown in Figure 9.

- If a Customer requires more cables or the total circuit exposure exceeds 1000 feet, the Customer shall provide suitable service equipment adjacent to the padmount transformer.
 1. This equipment shall consist of an outdoor cubicle with bus of a capacity to meet the transformer load and braced for the short circuit capacity.
 2. Each cable leaving this device shall have overcurrent protection.
 3. The service equipment shall be approved by the Company prior to fabrication.
- The neutral bushing of the transformer shall be connected by the Customer with full size neutral conductor(s) and grounded to the pad ground.

4.4.2 Vault Transformer – Utilizing Single Phase Transformers

- Bus duct is recommended for the connection between the transformer secondary terminals in the vault and the service equipment in the electric room. The bus duct enclosure shall be electrically continuous to the service equipment enclosure.
- The leads which connect the secondary bus to the transformer terminals shall be insulated stranded copper cable not smaller than the size listed in the National Electrical Code for "Single conductor in free air" for the current to be conducted when the transformer is carrying its rated kVA load.
- The neutral bushing of each transformer within a vault shall be connected by the Customer with a full size neutral conductor(s) external of the bus duct and grounded to the vault ground.

4.4.3 Terminations for padmount and single phase transformers

- All secondary connectors and connector fasteners shall be furnished, installed, owned and maintained by the Customer.
- Secondary connectors shall be listed for the purpose according to the NEC and meet the Company's requirements in Section 4.4.1 above and as follows.
 1. Minimum secondary conductor connector thickness shall be ¼ inch, with 9/16 inch diameter holes. Aluminum connectors shall be used with aluminum cable and bronze connectors shall be used with copper cable. Tin plated connectors can also be used as an alternate for aluminum and bronze connectors.
 2. Connector shall be a cable to flat clamp or compression type connector, with a minimum of two holes in the flat pad and two clamping elements or two compressions per cable.
- Secondary connector fasteners for use at the transformer terminals shall be stainless steel and listed for the purpose according to the NEC.
- Final torque tightening of the secondary connectors shall be completed by the customer.
- The Customer shall provide the Company with a written report of satisfactory installation acceptance tests of their service cables and connections to the secondary terminals of the Company's transformer prior to energization. See Checklists in Figure 14.
- The exposed live parts of the secondary connections may be required to be covered with electrical tape (or equivalent), by the customer, if deemed necessary by the company, to a thickness not less than 1/16 inch, where between live parts and live part-to-ground spacing has been compromised.

5.0 TRANSFORMER INSTALLATIONS ON CUSTOMER PREMISES [Excluding Underground Residential/Commercial Distribution (URD/UCD)]

5.1 Padmount Transformer Location

General:

- The Company will endeavor to work with the Customer to determine a mutually satisfactory location of the Company's transformer; however, the final location of the transformer shall be at the sole discretion of the Company.
- Where sufficient property exists, space separation shall always be used as the primary safeguard method to comply with **Rule 152A** of the **NESC** regarding the requirements of outdoor installed liquid-filled transformers. In no instance, will the Company rely on automatic extinguishing systems for installations on private property.
- As the Company's service point is the secondary terminals of the transformer, the transformer should be located as close as possible to the Customer's load center.

Proximity to Buildings:

The clearances to buildings and property lines shown in Figure 2 are chosen to achieve the necessary space separations for oil-insulated transformers installed outdoors in accordance with good utility practice. Where these space separations can not be achieved, additional safeguard methods such as oil containment and absorption systems, fire-resistant barriers, etc. may be considered by the Company if first approved in writing by the appropriate local authority having jurisdiction over fire prevention. In extreme cases, the transformer may need to be installed in a vault. To ensure the Company has adequate access to the transformer, under no circumstances will clearances be reduced to less than five (5) feet from the edge of the transformer pad or three (3) feet from the inside edge of the transformer

oil containment curb where used to the sides of the transformer. The minimum distance for the front of the transformer must be at least 10 feet.

- Clearances shall be measured from inside edge of transformer oil containment curb where oil containment is required.
- If the building has an overhang the distance to the inner edge of the transformer oil containment shall be measured horizontally from the outer edge of the overhang.

Proximity to Above Grade Facilities:

A horizontal clearance measuring ten (10) feet from the edge of the transformer pad shall be maintained to the closest point of all fire hydrants, cell towers, or other foreign objects.

A horizontal clearance measuring twenty-five (25) feet from the edge of the transformer pad or the inner edge of the transformer oil containment where used shall be maintained to the closest point of all above grade gas piping, fuel lines, and fuel storage tanks. Where this clearance can not be achieved, an additional safeguard such as a fire-resistant barrier shall be necessary and be approved in writing by the Fire Protection Code AHJ and shall not be less than five (5) feet from the edge of the transformer pad.

Proximity to Buried Facilities:

An area measuring ten (10) feet from the edge of the transformer pad or each inner edge of the transformer oil containment where used shall be maintained to the closest point of all buried waterlines, gas lines, sewer lines, communications circuits, other electric lines, storage tanks, etc.

Vehicular Traffic:

The Company will determine when bollards are required to protect transformer installations that may be exposed to vehicular traffic, grass cutting, or snow plowing equipment.

Any bollards that are required shall be provided and installed by the Customer as specified in Figure 2.

Transformer Oil:

Transformer installations on premises are subject to Company, local, state, and federal environmental rules and regulations. Where the Customer chooses or if the transformer location is near an environmentally protected area or there is risk of fire spread in space limited locations the transformer shall have oil spill containment. See Figure 4 for oil spill containment construction and spacing requirements. The following are considerations for when oil spill containment is necessary:

- Project location in National or State parks.
- Environmental resources or sensitive areas such as, but not limited to:
 - ✓ State or Federal regulated wetlands or adjacent areas as locally defined
 - ✓ River, stream, lake, pond or other water resources (beds, banks or waters)
 - ✓ Designated scenic highways or vistas
 - ✓ State forestlands or wildlife management areas
 - ✓ Other designated protection areas (nature preserves, refuges, parks, etc.)
 - ✓ Contaminated sites, including hazardous, industrial or solid waste disposal sites
 - ✓ Cultural Resources and state or federal historic preservation sites
 - ✓ Endangered Species
- Any special environmental interest groups having jurisdiction over or an interest in the project.
- In all cases, the company reserves the right to require oil containment.

Where vandalism is a concern, galvanized steel grating should be used on the surface of the crushed stone. This grating shall be bonded in two places with #2 AWG solid copper wire to the transformer ground grid.

Clear Working Area:

A minimum of ten (10) feet clear working distance shall be maintained in front of the doors for operating and maintenance of the transformer.

Bushes, trees, walls, fences, or other obstructions shall not be planted or installed in front of the doors.

The doors of padmounted transformers shall normally face the street.

Accessibility:

The transformer site shall always remain accessible to Company trucks equipped for the installation, removal and continued operation and maintenance of transformers.

Access ways to transformer sites in grass areas require a solid, well-drained base under the grass. The area should be capable of supporting trucks and equipment having a maximum bearing weight of 6,500 lb. per square foot without creating a depression of more than two (2) inches. If this criteria is not met by the Customer, appropriate fill material or steel plating will be required, as determined by Company personnel, and the Customer will be responsible for the cost of any such extra measures taken by the Company.

5.2 Padmount Transformer Foundation

1. The designs shown in Figure 5 are adequate for transformers up to 2500 kVA without primary switching.
2. For other cases the Company shall be consulted.
3. The transformer foundation shall be installed in the following manner:
 - a. Earth beneath the foundation shall be undisturbed or well tamped.
 - b. Number 2 crushed stone shall be installed in six (6) inch well tamped layers.
 - c. Concrete reinforcement shall be installed in accordance with the attached drawings.
 - d. Concrete shall have a minimum strength of 5000 psi.
 - Poured in place concrete shall be cured for 28 days.
 - Alternatively, “High-Early” concrete shall be cured for 7 days.
 - e. Precast foundations approved by the Company are acceptable.
4. Setting of the Company’s transformer shall occur once the Customer’s concrete pad has reached full strength. If the Customer requires the transformer set earlier but not less than 7 days, the Customer takes the risk of damaging their pad and delaying service to make the necessary replacement.
5. The Customer shall provide the Company with a written report of satisfactory installation of their foundation for the Company’s transformer prior to energization. See Checklists in Figure 14.

5.3 Vault Transformer Location, Design and Construction

5.3.1 General

This information describes the minimum structural, electrical, and mechanical requirements for the installation of a transformer vault by the Customer on private property. It is not intended to be a comprehensive document, and should be used only as a guide.

The vault shall be under the sole control of the Company and accessible to authorized Company employees at reasonable hours. No other persons shall be admitted to the vault after the transformers have been energized.

5.3.2 Vault Design and Location

It is the purpose of the transformer vault to isolate the transformers and other apparatus and to confine any fire that might be caused by the failure of any of the apparatus. The design, construction, and maintenance of the vault structure and its appurtenances shall reflect this concern of containment. Location of the vault access openings should be selected so as to minimize the possibility of injury in the event of a fire.

The vault shall be located above grade at an outside wall to permit good drainage, ventilation and access. It should be at a place which can be approached by a truck for delivery or replacement of transformers. A location at a parking or loading area is preferred.

5.3.3 Vault Construction

It is the Customer's responsibility to determine that the fire rating of the vault will meet all applicable codes and regulations for oil-filled transformers in a building.

General Notes:

1. Figures 7 and 8 show the typical vault construction for an application with single phase and padmount transformers.
2. The vault shall have an outside door, Class A, constructed in accordance with the National Electrical Code. All doors shall be secured with a hasp for a Company padlock. A sign reading "DANGER-HIGH VOLTAGE WITHIN-KEEP OUT-ACCESS RESTRICTED TO QUALIFIED PERSONS ONLY" shall be furnished and installed by the Company on the outside of all vault doors.
3. The vault shall be drained to an 8" X 8" X 4" sump with cover located adjacent to the personnel access door. It shall not be connected to a sewer system.
4. Other than fire suppression, no pipes, conduits or other building service equipment shall be contained within the vault.
5. The Customer shall furnish and install the primary cable support in the vault where indicated by the Company.

Fire Suppression:

Where required by the local and state building code and fire protection code, the Company will permit a water fire suppression system to be installed in the vault provided the Customer is responsible for and insures the following conditions are met.

1. The system shall be designed and installed so that there is no interference in the construction, operation, or maintenance of the vault or equipment therein. Location of all pipes, detectors, sprinkler heads, and nozzles shall not interfere with any of the Company's electrical equipment or access thereof. The system shall be designed so that it can be maintained without removal, relocation, or de-energizing of any Company equipment.
2. Where possible, while still meeting code requirements, the system shall be designed so that sprinkler discharge does not reach the Company's primary or secondary connections or any other energized uninsulated parts. Location of Company equipment will be shown on drawings provided to the Customer after the vault electrical design is complete.
3. Scaled drawings, prepared and sealed by the Customer's design professional, shall be provided showing location of sprinkler heads in the vault and calculated range of water dispersion from sprinkler heads relative to the Company's primary and secondary connections. All equipment shall be accurately located on the plans.

4. All construction shall conform to the design drawings reviewed and agreed to by the Company, and shall be inspected by a representative of the Company before the system is placed in service. The Company's engineer shall review and agree to any proposed deviation from plans already reviewed and agreed to by the Company.
5. Should a Code variance be required for any reason, it is the Customer's responsibility to obtain such variances from the appropriate authority having jurisdiction and provide written notice to the Company.
6. The Customer assumes sole responsibility for proper operation of the fire suppression system.
7. The Company assumes no liability for any result or consequences of a fire suppression system that has the potential to apply water on an oil or silicone insulating fluid fire.
8. The Customer shall indemnify and hold the Company harmless for any damages resulting from operation, misoperation, or inadvertent system discharge of a fire suppression system. This indemnification shall be formalized and executed in an agreement between the Customer and the Company.
9. Should the system misoperate or discharge unnecessarily, the Customer will be responsible for vault cleanup and any costs incurred by the Company.

Walls, Roof, and Floor:

1. The quality of materials used in vault construction shall be of approved grade, as determined by the applicable codes and standards. Building walls, roof and floor (new or existing) meeting the requirements in this section may serve as part of the vault.
2. The vault in its entirety shall be solid masonry or concrete construction having a minimum 3-hour fire rating according to the National Electrical Code.
3. Walls shall be continuous and free of holes, deep scars, cracks, or other breaks. Seals shall be fire rated approved materials.
4. The floor shall be a level surface, adequately reinforced to support loads specified by the Company for its equipment.
5. Should the Customer be concerned about any possible undesirable sound or vibration transmission to other portions of the building, any soundproofing is their responsibility. Should the Customer desire to support the transformers on soundproofing devices, any device should be fabricated so as not to exceed 2" thickness and so that it will hold its dimensions over time given the weights involved and variation in vault temperature.

Ventilation:

1. Vaults shall be ventilated to the outside through openings that are located, arranged, sized, covered, and constructed in accordance with the National Electrical Code and specific requirements noted below. The exhaust area shall not be less than the inlet area. A roof type exhaust ventilator is preferred for one-story structures.
2. Ventilation capacity shall be furnished for the maximum transformer capacity of the vault, even though the initial transformer installation may be less than maximum capacity. The ventilation design shall be submitted to the Company for review.
3. Extreme caution shall be exercised in the design, routing, and installation of ventilating systems. Exhaust openings to outside walls should not be located adjacent to other openings that serve or could serve as air intakes. Exhaust openings should be located as far as possible from doors, windows, fire escapes, and combustible material, and at an adequate elevation above grade. Duct facilities should not be routed through areas where system leaks (possibly initiated by explosion) could result in the escape of potentially toxic gases or residue to occupied areas.
4. Intake and exhaust openings shall be equipped with rustproof metal louvers and 1/2" mesh rustproof screens where they meet the outside air. The exhaust ducts shall be located high in the vault and the intake ducts low a minimum of 4 inches above final grade or floor, both suitably spaced to provide air circulation around transformers. Fire

dampers, when required by the local and state building code and fire protection code, shall be #10 gauge galvanized steel minimum constructed in accordance with ANSI/UL 555 "Standard for Fire Dampers". Links shall allow dampers to fall or rotate closed in the event of fire, but not as a result of excessive transformer temperature. In addition, the dampers shall be arranged so that operation of a forced air blower does not hold them open.

5. If a forced air ventilation system is required, the Customer will, at their expense, install, maintain, and provide energy for a thermostatically-controlled ventilation system designed to move outside air through the vault.
6. Power supply to the blower shall be connected from the load side of the Customer's meter. An adjustable thermostatic control shall be provided for automatic operation, with a manual on/off switch. Controls and a safety switch shall be located inside the vault near the door. All other ventilation equipment should be externally located.

5.3.4 Vault Maintenance

Should the vault require maintenance, it will be brought to the attention of the Customer and shall be promptly repaired with a Company representative in attendance.

1. Customer access to Company controlled electrical spaces within Customer-owned electric facilities:

The Company's control of electric spaces in Customer-owned electric facilities is for the sole purpose of protecting the integrity of the Company's energy supply and security of the utility metering equipment. Any costs shall be determined by the Company's filed tariff. In these requirements, "Customer" refers to the Customer or their agent. Under this and all other policies, it is expected and it is the Customer's responsibility to provide a qualified person as defined in the National Electrical Code and any other applicable codes.

- a. The Company can provide isolation and tagging (and grounding upon customer request), if requested, at the Company's primary isolation point on the supply line ahead of the Customer's service equipment. However, the Customer is solely responsible for the protection of personnel who work on their de-energized equipment.
 - b. When the Customer does not require isolation and tagging on the supply line and needs access to Company-controlled electrical spaces for their maintenance purposes, the Company in its sole judgment may determine the ability to grant access to the Customer for the duration established by the Company. When granted, the Company will witness the Customer's placement of their lock immediately after the removal of the Company's lock. Upon notification by the Customer that their work is complete, the Customer shall relinquish access back to the Company and the Company's lock shall be placed immediately upon the removal of the Customer's lock. In each case the transfer shall occur in the presence of both parties. The Company will check its electrical equipment for any signs of tampering.
2. In the event that the required access is of short duration and the Company's representative remains on site to avoid a second trip, it is understood they are doing so without any supervisory or oversight capacity relative to the Customer.

5.4 Service Operating Procedures

The Customer is responsible for having qualified personnel available at all times to perform the operating functions for their service equipment.

6.0 GROUNDING

The following grounding criteria are for the sole purpose of grounding the Company-owned transformer and based on a moist, sand-clay soil type. The Customer is responsible for installing their own service entrance ground in accordance with Section 6 of ESB 750 and the NEC. The Customer may install the ground grid with approved materials exceeding the minimum criteria below for situations such as varying soil conditions and special requirements specified by an authority having jurisdiction.

6.1 Padmounted Ground Grid Installation

- A ground grid shall be installed by the Customer, consisting of bare copper conductor soft drawn 19 strand, minimum size #2/0 AWG, buried in the pattern of an outer loop around the transformer pad. Refer to Figure 3.
- The loop shall be connected to at least 2 driven ground rods (one at each opposite corner) at not less than eight (8) feet from each other. If ground rods cannot be driven, consult the Company for an alternate design that allows the installation of a counterpoise system.
- Two grounding connections shall be provided by the Customer from the ground grid to the transformer.
- A length of conductor, at least 3 feet above the top of the pad, shall be provided for each connection.
- The ground connections to the transformer tank will be made by the Company.
- Metallic primary and secondary conduits shall be bonded by the Customer to the ground grid with #4 AWG Cu (solid).
- Where practicable, the ground grid shall be bonded to a continuous metallic water system.
- Ground connections shall be exothermic or pressed type.

6.2 Vault Ground Grid Installation

Ground rods and a continuous #4/0 AWG bare copper or equivalent ground bus shall be furnished and installed in the vault by the Customer as shown in Figure 3. Non-current carrying metallic parts of equipment in the vault will be connected to the vault ground. Where practicable, the vault ground shall be bonded to a continuous metallic water system or building ground by the Customer.

6.3 Ground Grid Resistance for Installations Supplied from delta 2.4kV, 4.8kV, 12kV and all 23kV and 34.5kV systems

For delta systems less than 15kV, the ground grid installed by the Customer shall have a ground grid resistance of 25 ohms or less. For all systems greater than 15kV, the ground grid resistance shall be determined by the Company.

The ground resistance of the ground grid shall be verified by the Customer in accordance with IEEE Standard 81 before connection to the water pipe or other grounding systems. The test shall be performed using a Biddle ground tester, or by other suitable means, to be assured that the ground resistance is no greater than the value specified by the Company. A copy of the test results shall be provided to the Company.

Ground grids not achieving the values prescribed by the Company shall be augmented with additional ground rods installed a minimum of 8 feet from the existing ground rods and connected to the transformer ground grid with a minimum #2/0 AWG copper soft drawn 19 strand.

6.4 Ground Grid Resistance for Installations Supplied from wye 5kV Class and 15kV Class Systems

Due to the nature of these continuously grounded distribution systems, the grounding method described in section 6.1 is sufficient protection and does not need to be measured or augmented.

6.5 Ground Grid Integrity

It is the Customer's responsibility to ensure the integrity of their ground grid to meet ground grid resistance requirements and longevity of the installation.

7.0 CUSTOMER'S SERVICE EQUIPMENT and COMPANY METERING

- Service equipment and metering transformers shall not be installed in the transformer vault.
- Refer to ESB 750 Sections 5 and 9 for the Customer's service equipment installation requirements.
- Refer to ESB 750 Section 7 for the Customer's provisions to be made for the Company's metering.

8.0 PRE-ENERGIZATION REQUIREMENTS

The Customer shall provide the Company with a written report of satisfactory installation including the checklists completed in Figure 14 as a minimum. This shall be submitted upon the issuance of the third party electrical inspection approval certificate for the service connection.

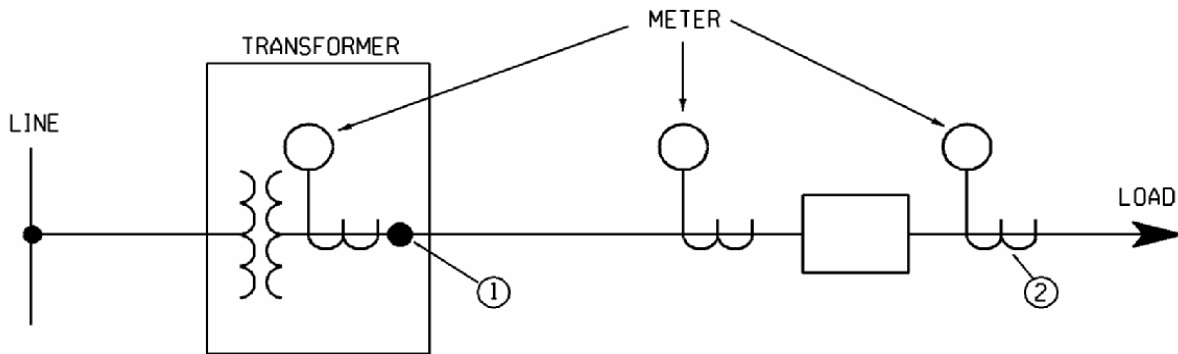

PRIMARY SUPPLY	PADMOUNT LOCATION & FOUNDATION	SECONDARY CABLE & CONDUIT	MAIN SERVICE EQUIPMENT	METERING
BULLETIN REFERENCE:	BULLETIN REFERENCE:	BULLETIN REFERENCE:	BULLETIN REFERENCE:	BULLETIN REFERENCE:
SECTION 4.0	SECTION 4.0 SECTION 5.0 SECTION 6.0	SECTION 4.0	SECTION 7.0	SECTION 7.0

NOTES

1. Secondary terminal connection point inside padmount transformer
2. Cold sequence connection required for metering CT's and self contained meter sockets when more than one tenant customer is served from the premise owner's service connection

FIGURE 1 SERVICE INSTALLATION DIAGRAM – THREE PHASE PADMOUNTED TRANSFORMER

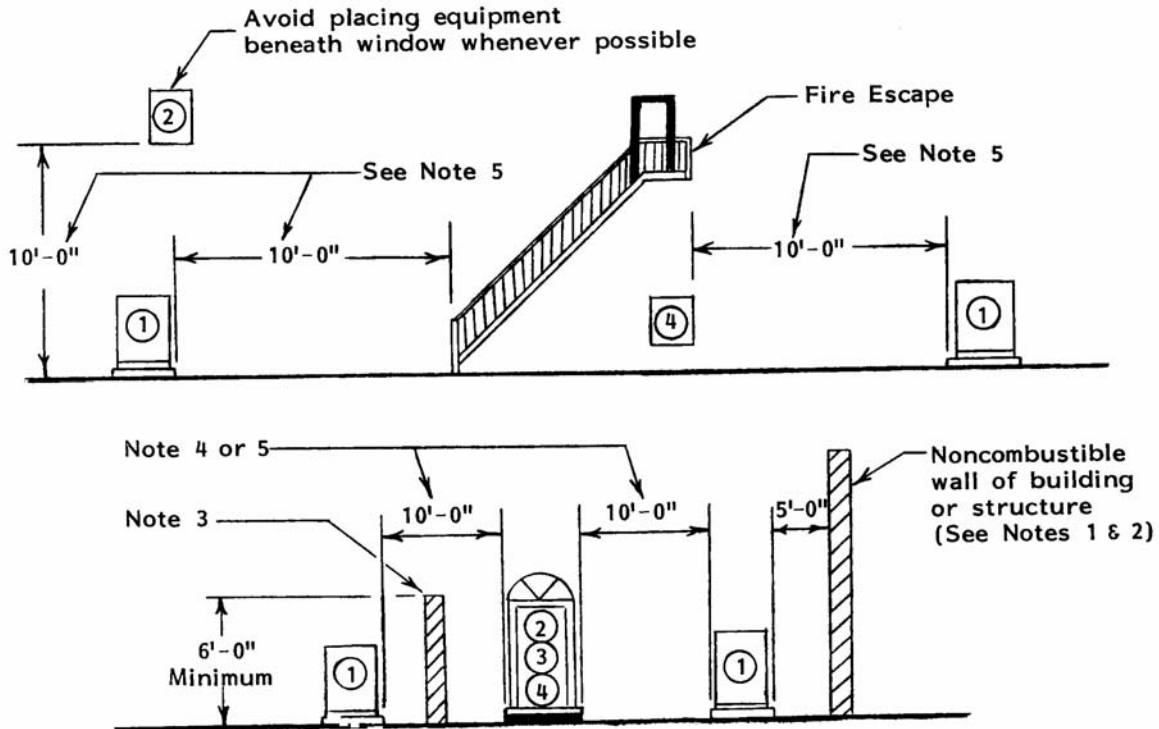

Legend	
①	Equipment, oil insulated
②	Window
③	Door
④	Ventilating Duct

Notes:

1. Noncombustible material is defined as a material that will not ignite, burn, support combustion or release flammable vapors, when subjected to fire or heat, or as described by the latest edition of the NFPA-220.
2. No portion of a building or building structure shall overhang any part of the pad-mounted equipment.
3. In cases where required distances cannot be met, a noncombustible barrier, 6 foot minimum height, shall be constructed. This barrier shall be designed to provide adequate fire protection to the existing structure. A design for this structure shall be prepared and sealed by the customer's Professional Engineer or Registered Architect and shall further be approved by the local authority having jurisdiction of building code enforcement.
4. For exits from a public assembly room, such as an auditorium, a 10 foot minimum clearance should be increased to 25 feet, unless there is a barrier.
5. This requirement may vary between individual states. Refer to the building code regulations for the state involved.

FIGURE 2

**THREE-PHASE PADMOUNTED TRANSFORMER
REQUIRED CLEARANCES**

6. Clearances from objects:

A. An area measuring 10 feet from any point of the transformer pad shall be kept free of all:

- buried water lines, storm drainage lines, gas lines, other electric lines;
- underground fuel storage tanks; and
- above grade fire hydrants, cell towers, self contained diesel or diesel byproduct fueled generators, and outdoor enclosed generators.

B. An area measuring 25 feet from any point of the transformer pad shall be kept free of all:

- exposed water lines, gas piping, sewer lines;
- open conductor electric lines; and
- above grade gas meters or regulator vents, fuel storage tanks or dispensing units, and non-enclosed gasoline fueled generators.

NOTE: The 25 ft. clearance may be reduced to 10 ft. with a noncombustible barrier (see Note 3) and shall not be less than five (5) feet from the edge of the transformer pad. The Customer or their authorized representative shall obtain this clearance reduction approval from the Company and the local AHJ, as necessary, prior to the noncombustible barrier installation.”

Figure 2 (cont'd)

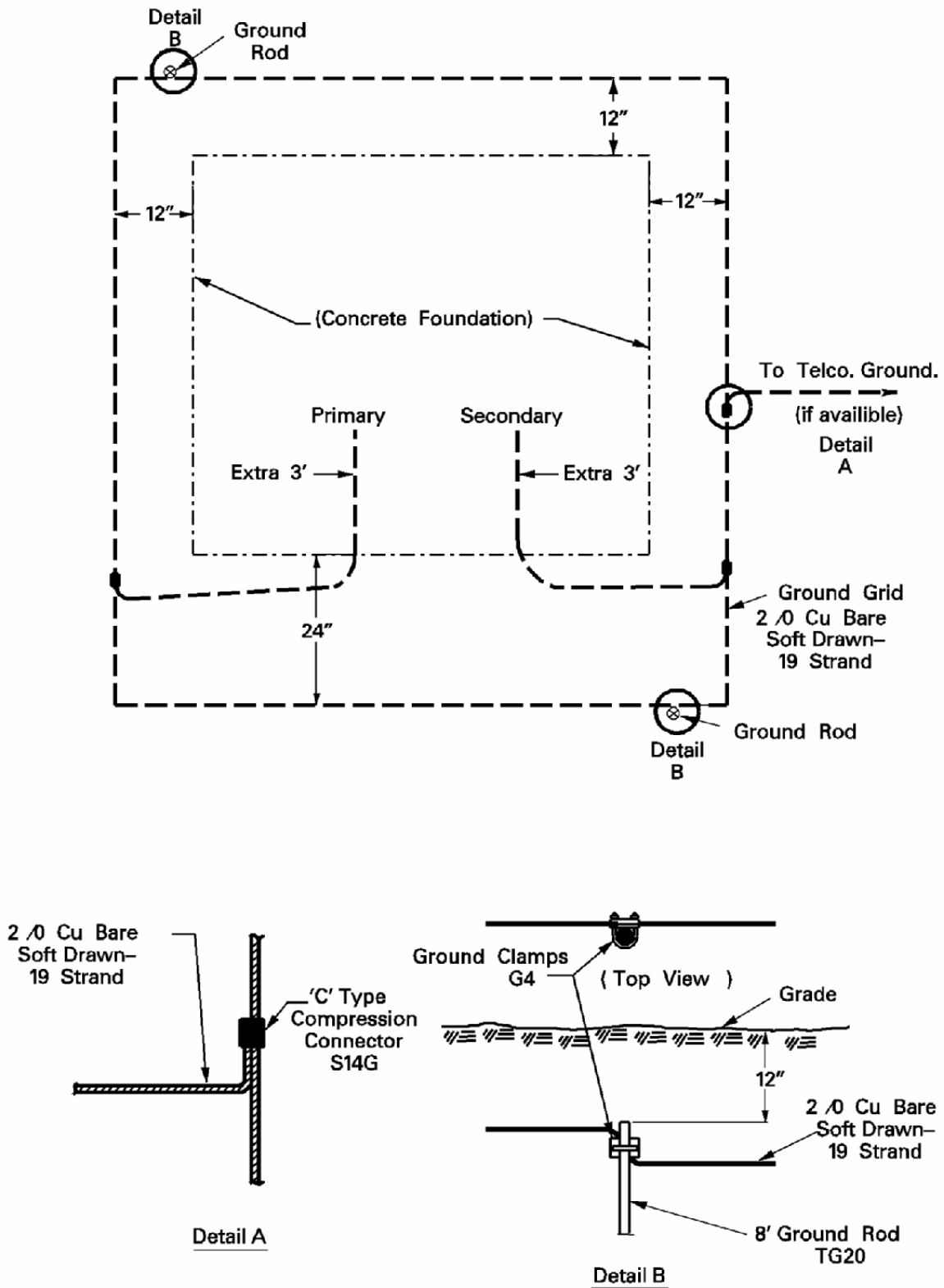
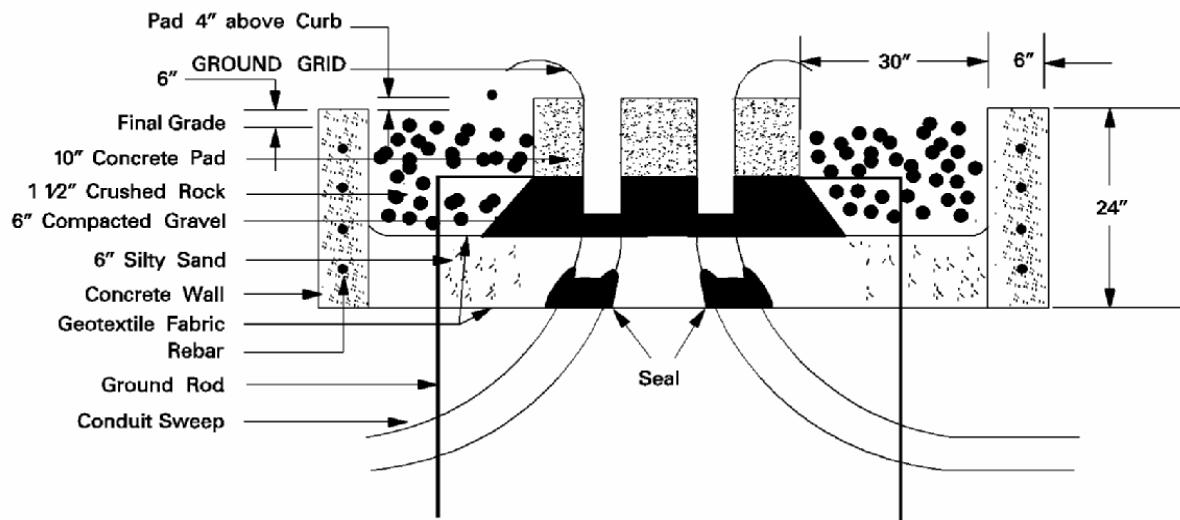
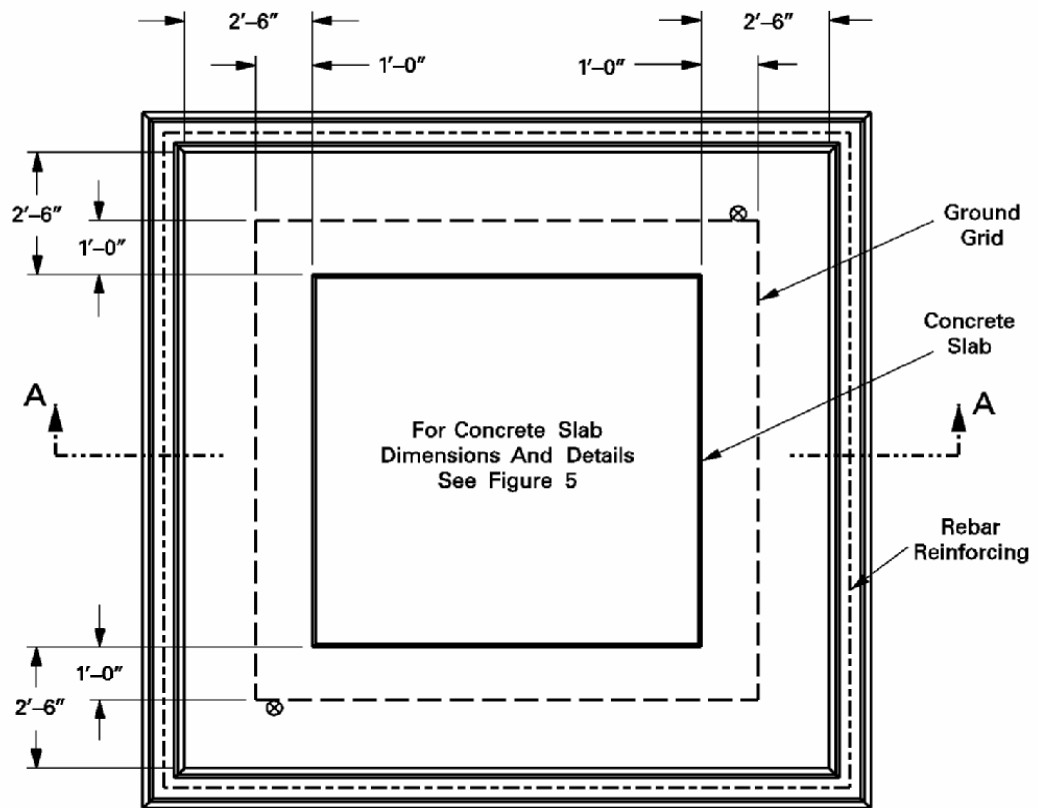

FIGURE 3

GROUNDING PLAN
THREE-PHASE PADMOUNTED TRANSFORMER



Typical Detail

FIGURE 4

OIL CONTAINMENT CURB (IF REQUIRED)

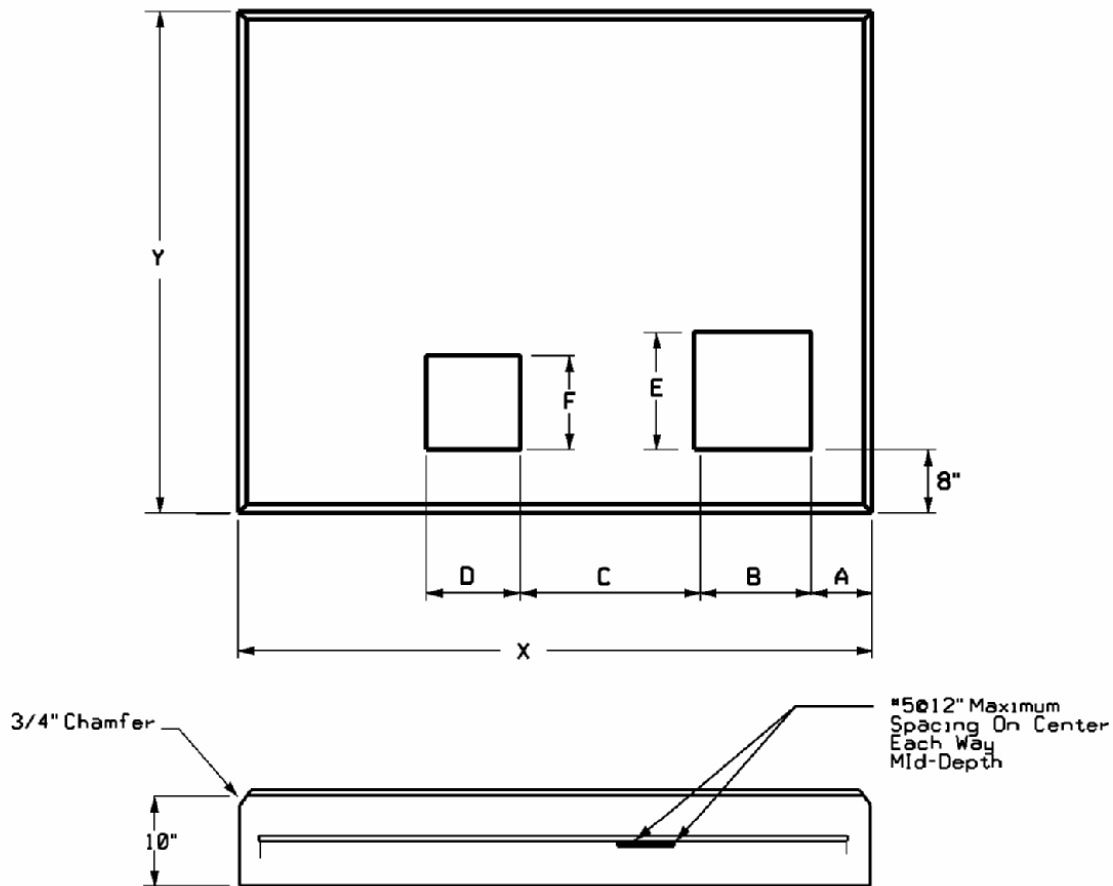

REBAR DIAGRAM

3 PHASE PADMOUNTS		15 kV		25 and 35kV	
Dimensions		75-500kVA	750-2500kVA	75-300kVA	500-2500kVA
X		81"	83"	85"	96"
Y		64"	82"	62"	84"
A		22"	12"	8"	8"
B		15"	25"	15"	25"
C		8"	8"	20"	20"
D		12"	12"	12"	12"
E		15"	15"	18"	21"
F		12"	12"	12"	12"

Notes:

1. All materials and workmanship shall conform to ACI-318.
2. Concrete to have a minimum strength of 5000 p.s.i. after 28 days.
Air entrainment to be $6\% \pm 1\%$. All exposed edges to have a $\frac{3}{4}$ " chamfer.
3. Reinforcing to be #5 - Grade 60 bars and shall conform to ASTM A-615 of latest date.
Reinforcing to be placed a minimum of 2" clear from face of concrete.
4. All openings shall have additional rebar reinforcement of 1 - #5 each corner, mid-depth.
5. Lifting anchors shall be installed with appropriate Dayton lifting anchors or equivalent.

FIGURE 5

TYPICAL TRANSFORMER CONCRETE PAD DIMENSIONS

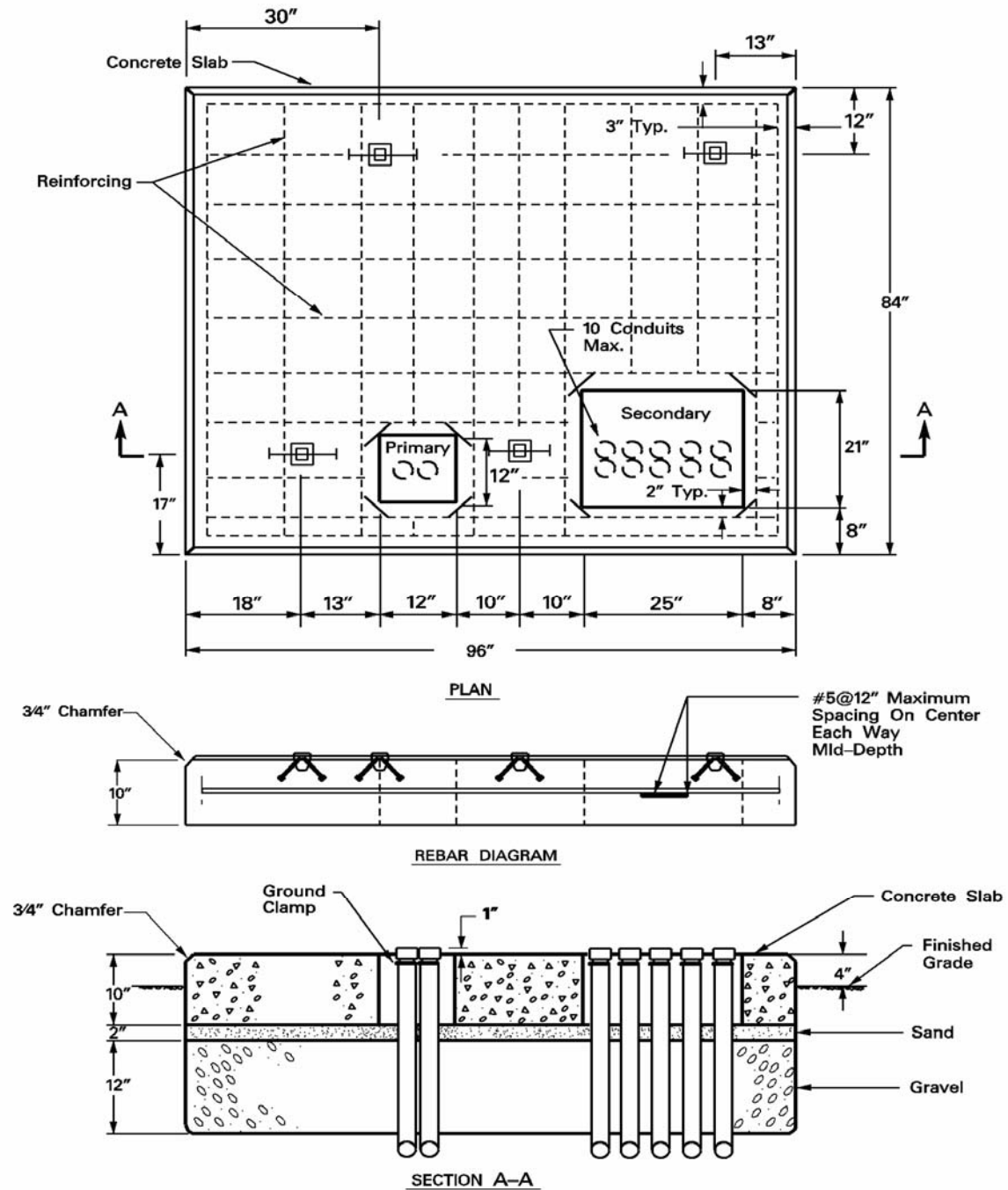

NOTE: Customer shall seal secondary conduits with expanding foam and shall also grout primary and secondary conduit openings on pad. Company shall seal primary conduits as deemed necessary.

FIGURE 6 Reinforced Concrete Flat Pad Three-Phase, Padmounted Transformers (Typical Conduit and Foundation Reinforcing Schedule)

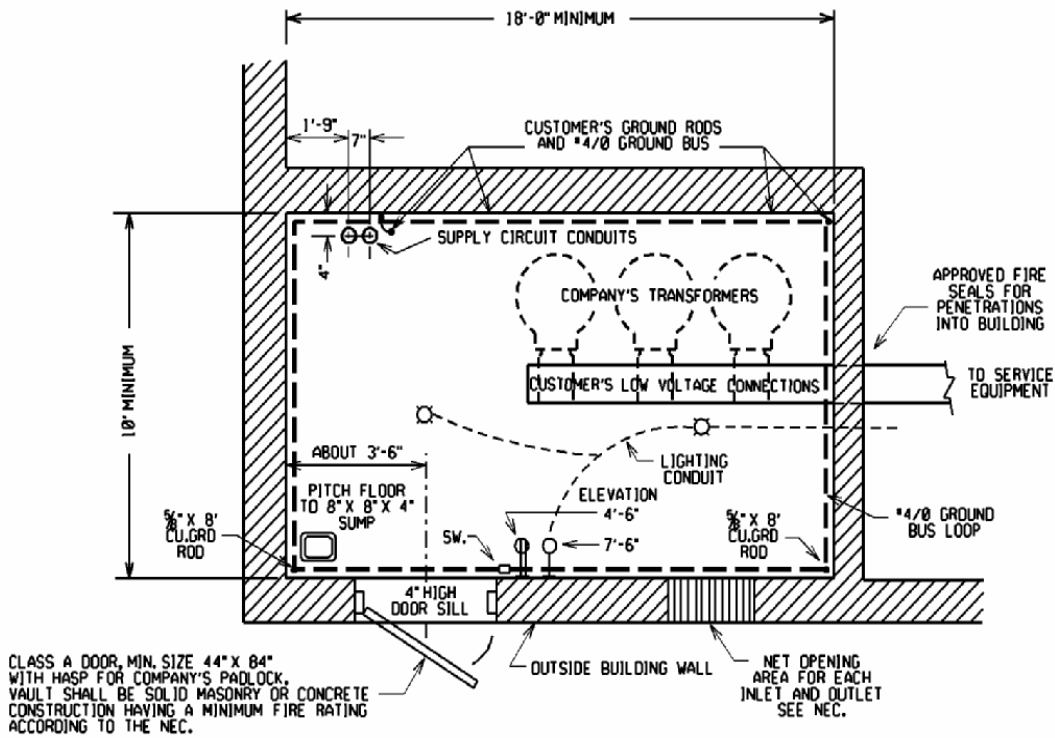

PLAN

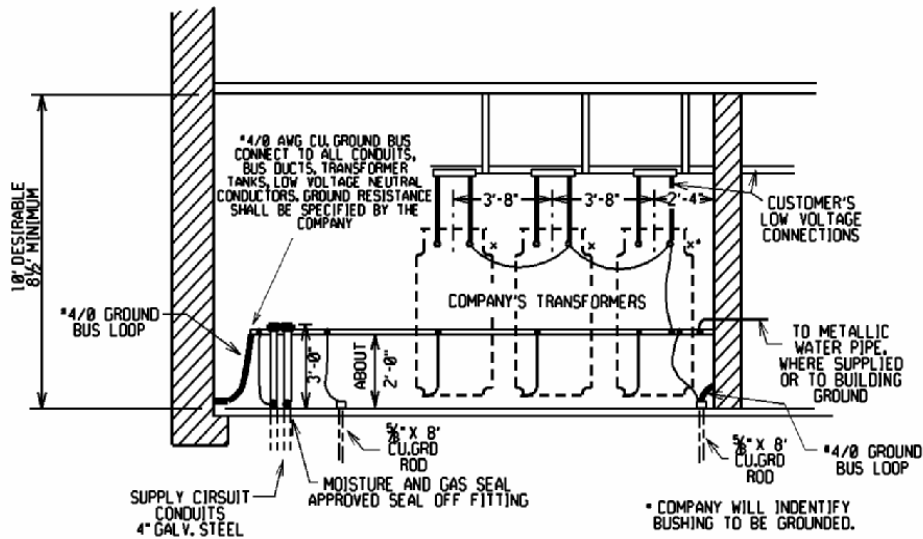

ELEVATION

Typical Above Grade Transformer Vault
Customer's Three Phase Service Less Than 600V

FIGURE 7

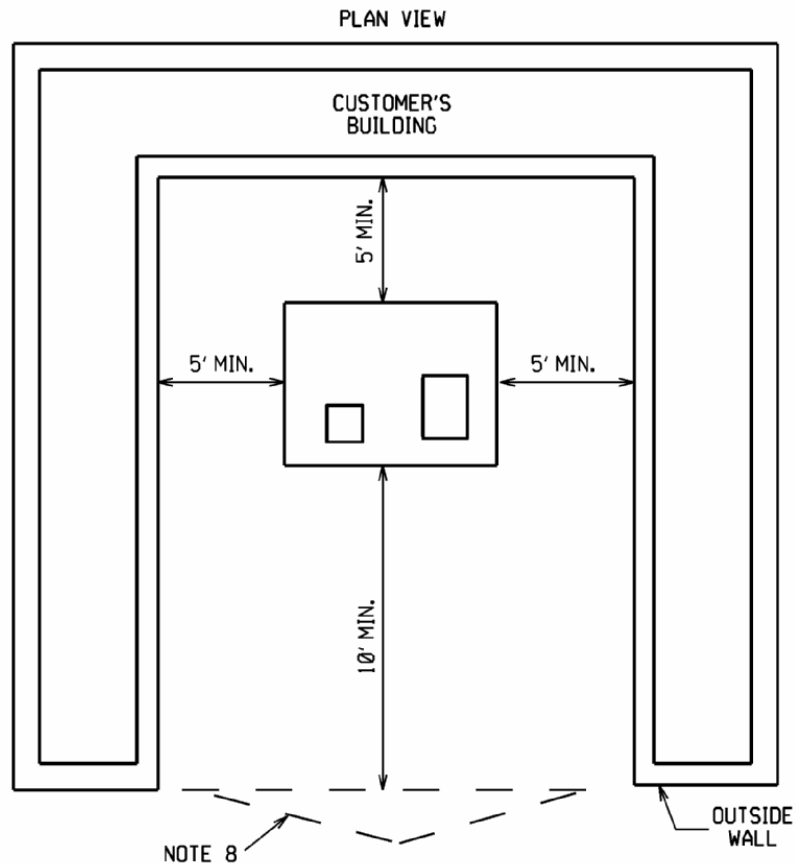

NOTES:

1. Raised concrete pad reinforced with welded wire fabric with dimensions as shown in figure 8, except pad shall be 4 inches above the floor.
2. Conduits to be arranged as shown in Figure 6 and installed to 1" above top of the pad. Conduit entry shall be designed to prevent oil from spilling into other parts of the building.
3. Vaults with padmount transformers do not have to be secured.
4. For vaults with no outside wall, a 4 inch curb shall be installed. If the top of the curb is 4 feet or more above the adjoining outside area a removable handrail shall be provided along with a 36" wide stairway for access to the vault. The top step of the stairway or landing shall be at the same elevation as the curb.
5. For vaults with an outside wall, the opening for the padmount transformer installation shall be the same height as the vault ceiling and six feet wider than the transformer pad. The opening shall be centered on the transformer pad.
6. Vault height shall be determined by the Company based on the transformer size and access to the area in front of the vault by Company vehicles.
7. Dotted line in drawing shows required fence, for installations that are not enclosed by the building for transformer and equipment that is not padmounted.
8. Fence installations shall have a 10' wide X 12' high door located in front of transformer for maintenance of equipment.

FIGURE 8 Typical Above Grade Transformer Vault with Padmounted Transformer – Customer’s Three Phase Service Less Than 600V

SIDE VIEW FIG #8

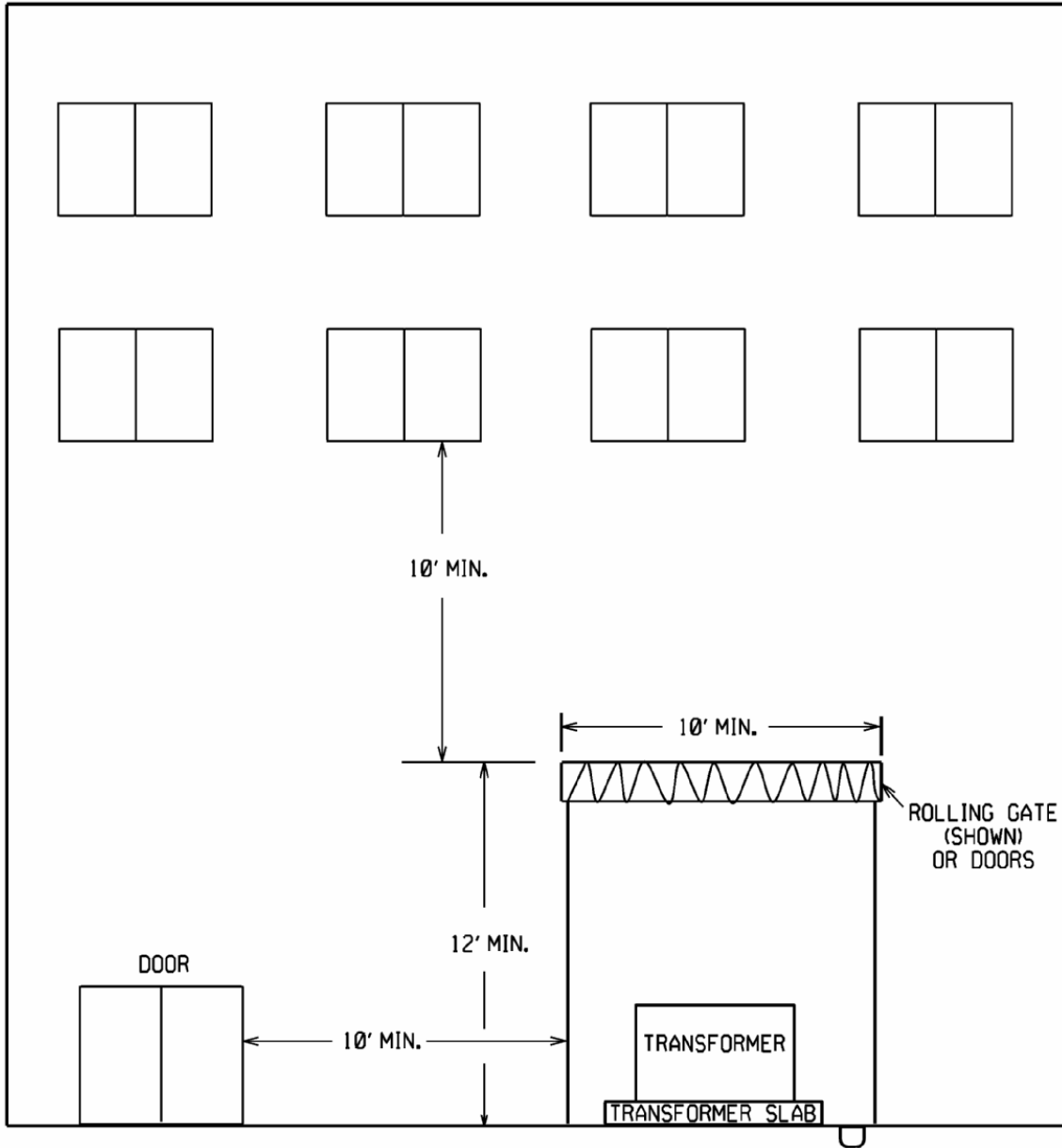
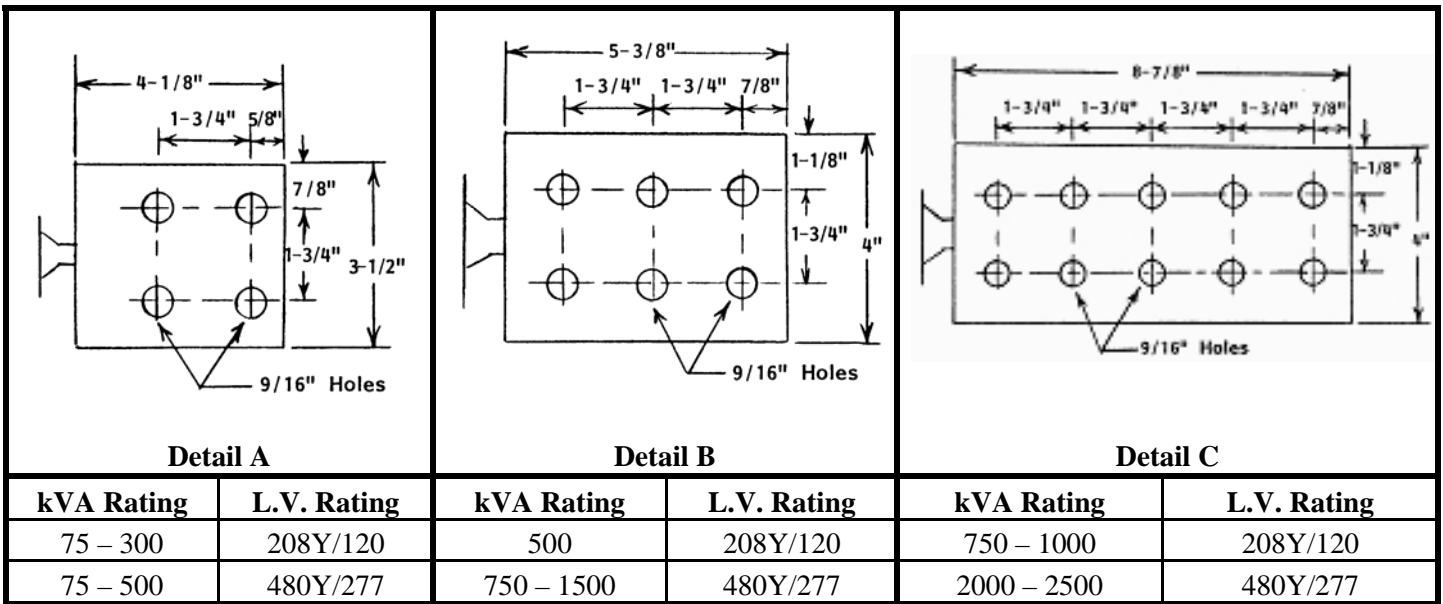

FIGURE 8
(Cont'd)

Typical Above Grade Transformer Vault with Padmounted
Transformer – Customer's Three Phase Service Less Than 600V
VERTICAL PROFILE



All Company padmounted transformer spade terminals are shown in Details A, B, and C. Minimum secondary conductor connector thickness shall be 1/4 inch, with 9/16 inch diameter holes.

FIGURE 9

Secondary Connections to Padmounted Transformers

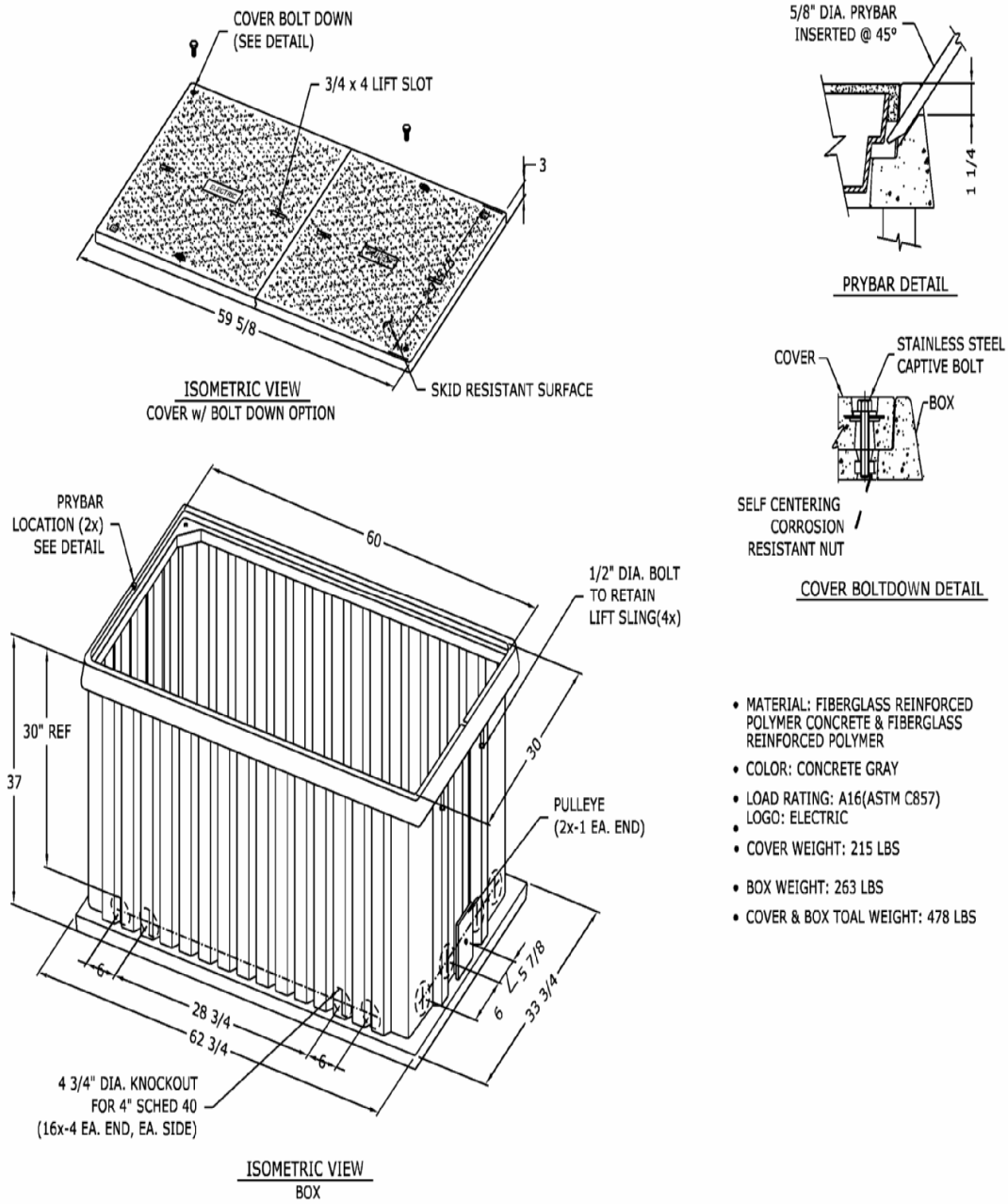

- MATERIAL: FIBERGLASS REINFORCED POLYMER CONCRETE & FIBERGLASS REINFORCED POLYMER
- COLOR: CONCRETE GRAY
- LOAD RATING: A16(ASTM C857)
- LOGO: ELECTRIC
- COVER WEIGHT: 215 LBS
- BOX WEIGHT: 263 LBS
- COVER & BOX TOAL WEIGHT: 478 LBS

FIGURE 10 Typical Primary Cable Handhole Construction

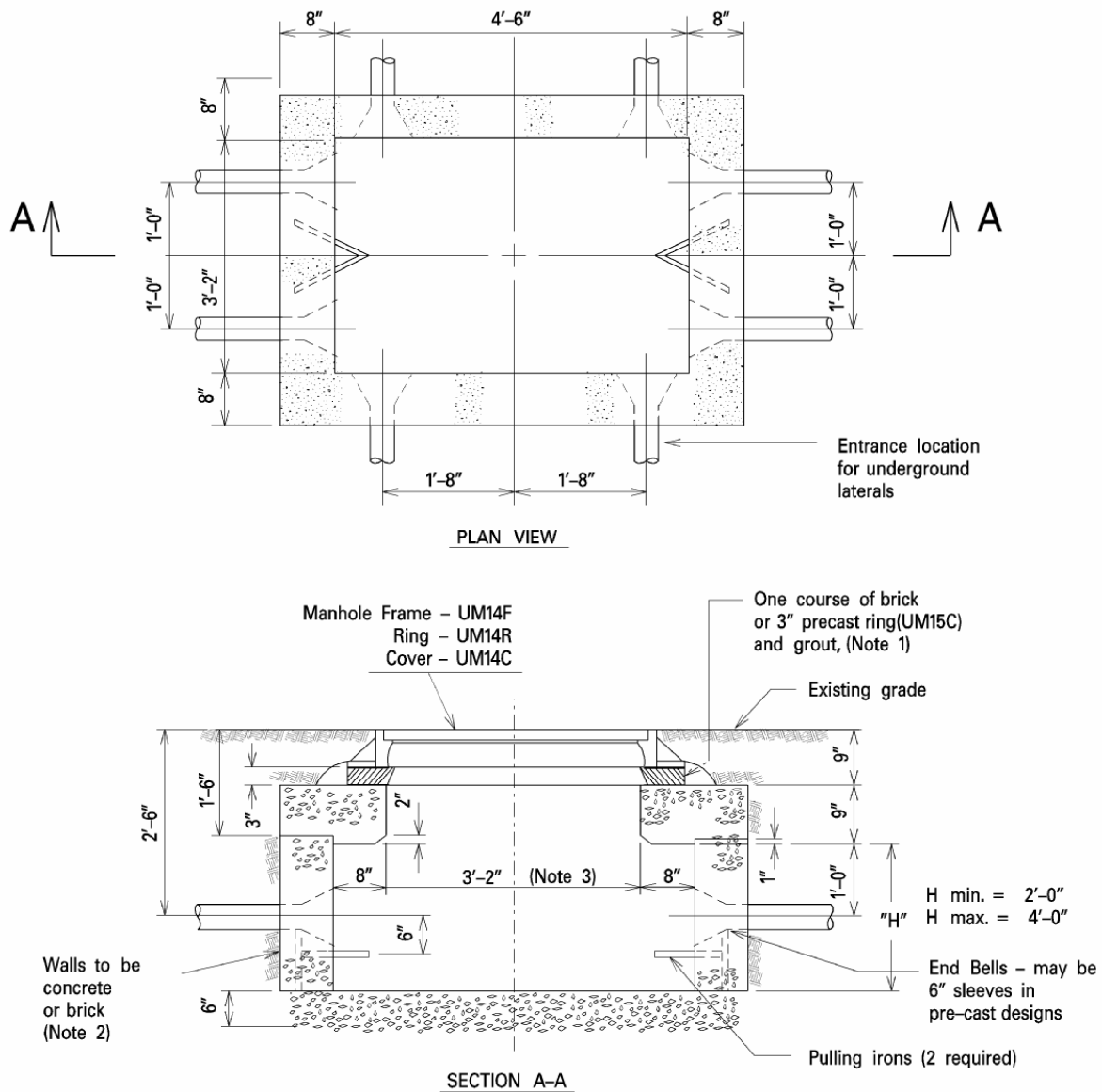

NOTE: Where splicing is necessary for one set of #4/0AWG cables, a heavy duty handhole may be used as shown. For multiple sets of #4/0AWG cables, or cables larger than #4/0AWG a manhole, per Figure 11, shall be used.

FIGURE 10 Typical "Heavy Duty" Primary Cable Handhole Construction (cont'd)

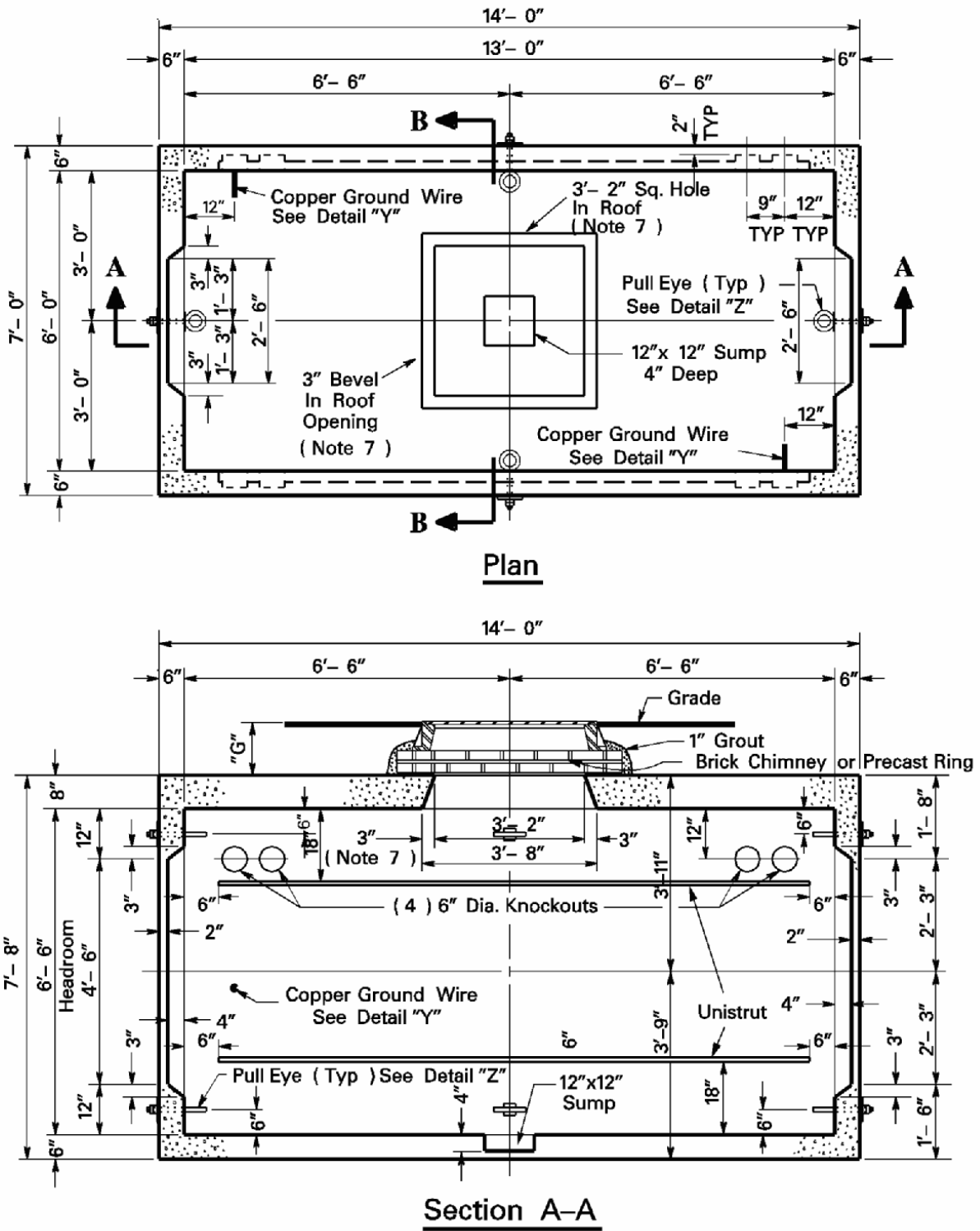
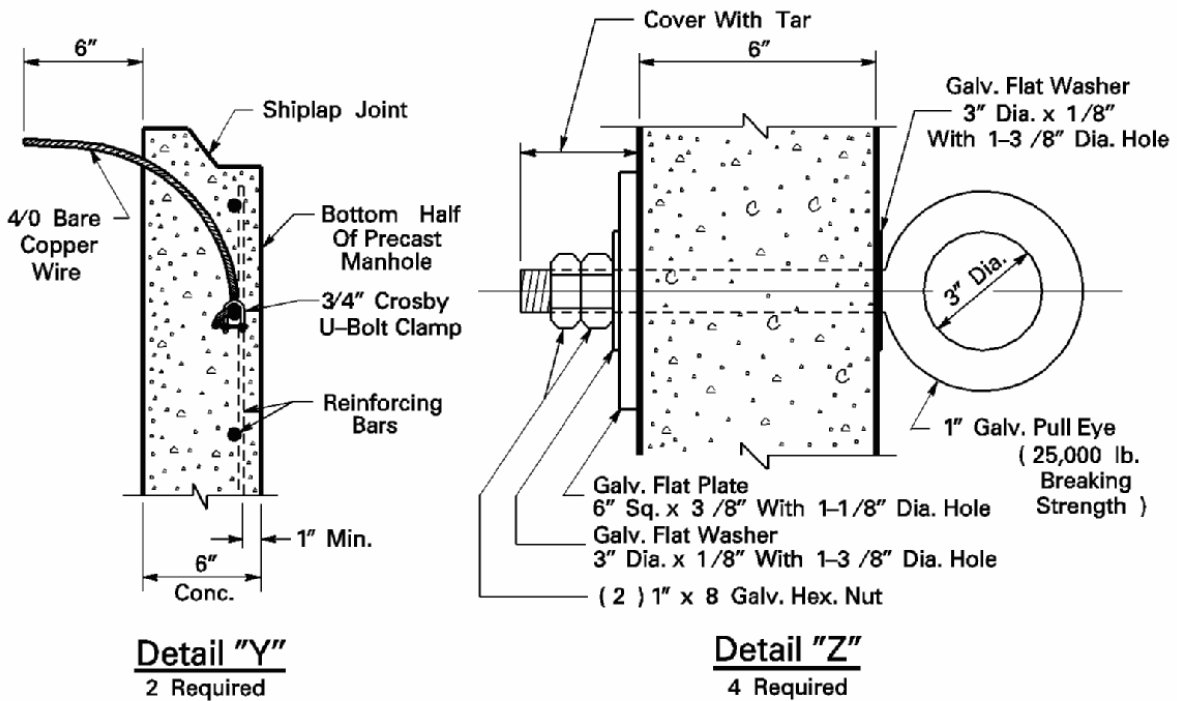
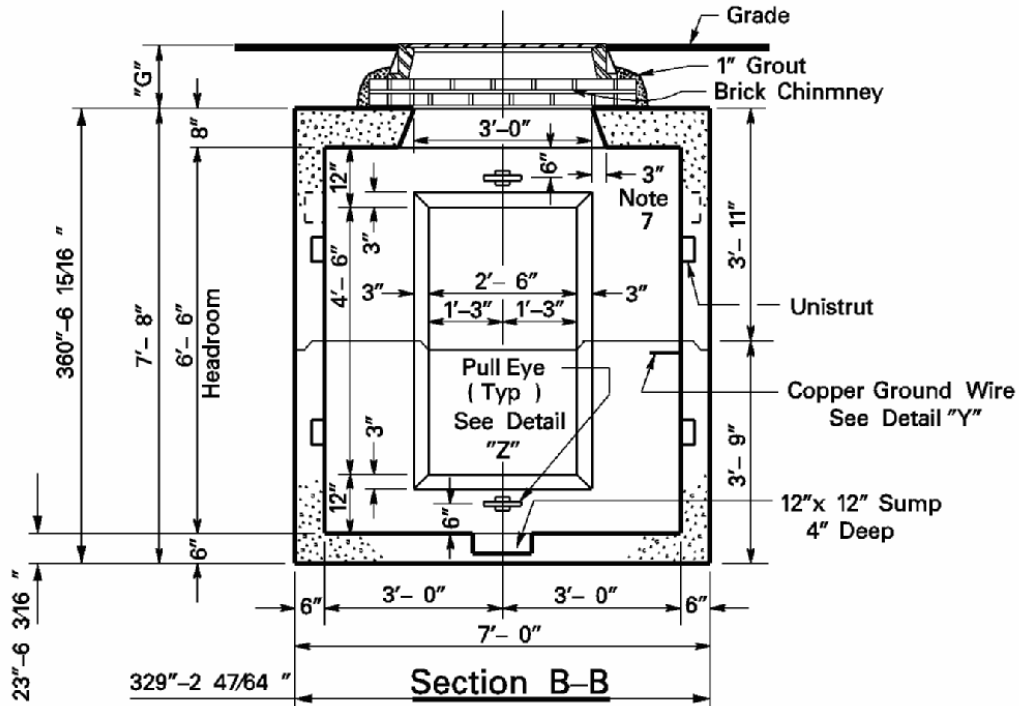

FIGURE 11

Typical Manhole Requirements



Note: Construction joint to be sealed with asphalt or equivalent.

Figure 11 (cont'd)

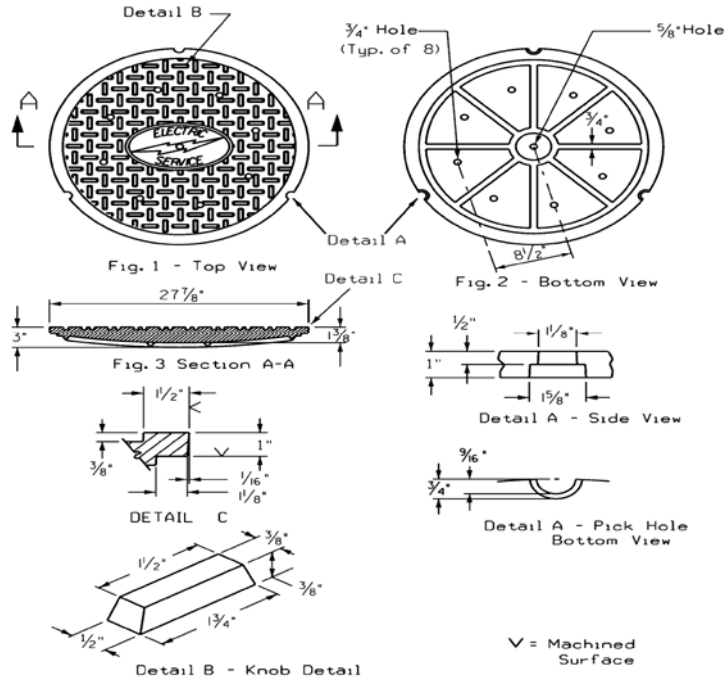

26" MH Cover

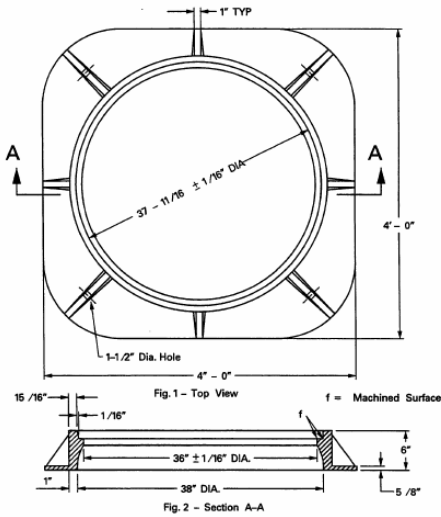

36" MH Frame

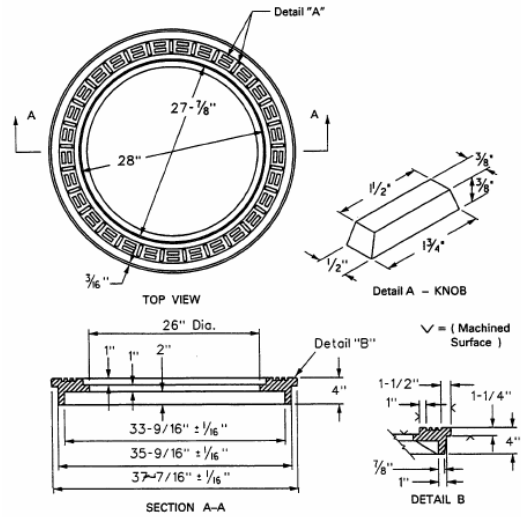

26" - 36" MH Ring

Figure 11 (cont'd)

NOTES

1. Concrete minimum strength - 5000 P.S.I., 28 days
2. Steel reinforcing bars shall conform to ASTM-A-615 (latest revision). Grade 60 min. Cover - 1".
3. Design loading - the roof shall be designed for AASHO-HS20-44 direct wheel loading.
4. Do not extend horizontal rods into duct openings. Vertical reinforcing rods in top and bottom sections of the duct openings will be bent out in the field for support of incoming duct bank.
5. Pull eyes, furnished by manufacturer, to be 1" round galvanized eye bolt. Pull test 25,000 lbs. As per detail "Z".
6. Bare 4/0 copper ground stub conductor and U-bolt clamps as shown in detail "Y" to be furnished by manufacturer.
7. Manholes to be supplied with a 3'-2" square hole in roof with a bevel between 1 ½" and 3" as standard.
8. Construction joint shall be sealed with asphalt or equivalent.
9. Customer will provide manhole frame, cover, end bells and brick.
10. Manholes to be in accordance with ASTM publication C-857 and C-858.
11. Manhole to be delivered to the job site by the manufacturer. Delivery to be coordinated by the Customer.
12. Unistrut to be 1-5/8" x 1-5/8" galvanized steel.

Figure 11 (cont'd)

- NOTE #1 Insulating bushing.
- NOTE #2 Galvanized steel conduit and bend are to be used, they shall be grounded by bonding to an approved U-bolt type ground clamp 6" (150 mm) from top of the conduit. A 24" (600 mm) conductor shall be provided to extend to the Company's grounding conductor. The conductor shall be sized as required by the National Electrical Code, Article 250, but in no case shall it be smaller than #4 AWG copper. Recommend use of corrosion resistant bend in locations subject to highway salting. See Section 4.1.9 in EB 750.
- NOTE #3 Galvanized steel conduit, galvanized steel sweep, attachment clamps, grounding clamp and 24" grounding conductor shall be furnished and installed by Customer. Normally, the conduit shall rise on the side of the pole away from traffic up to 8 ft. (2.5 m) to 11 ft. (3.4 m). Consult company for proper location on pole.
- NOTE #4 Pipe straps, install at not more than 30" (750 mm) intervals.
- NOTE #5 The conduit burial depth shall be 30" (750 mm) minimum.
- NOTE #6 See Section 4.3.2 for all aspects related to underground primary service lateral connections from overhead lines.

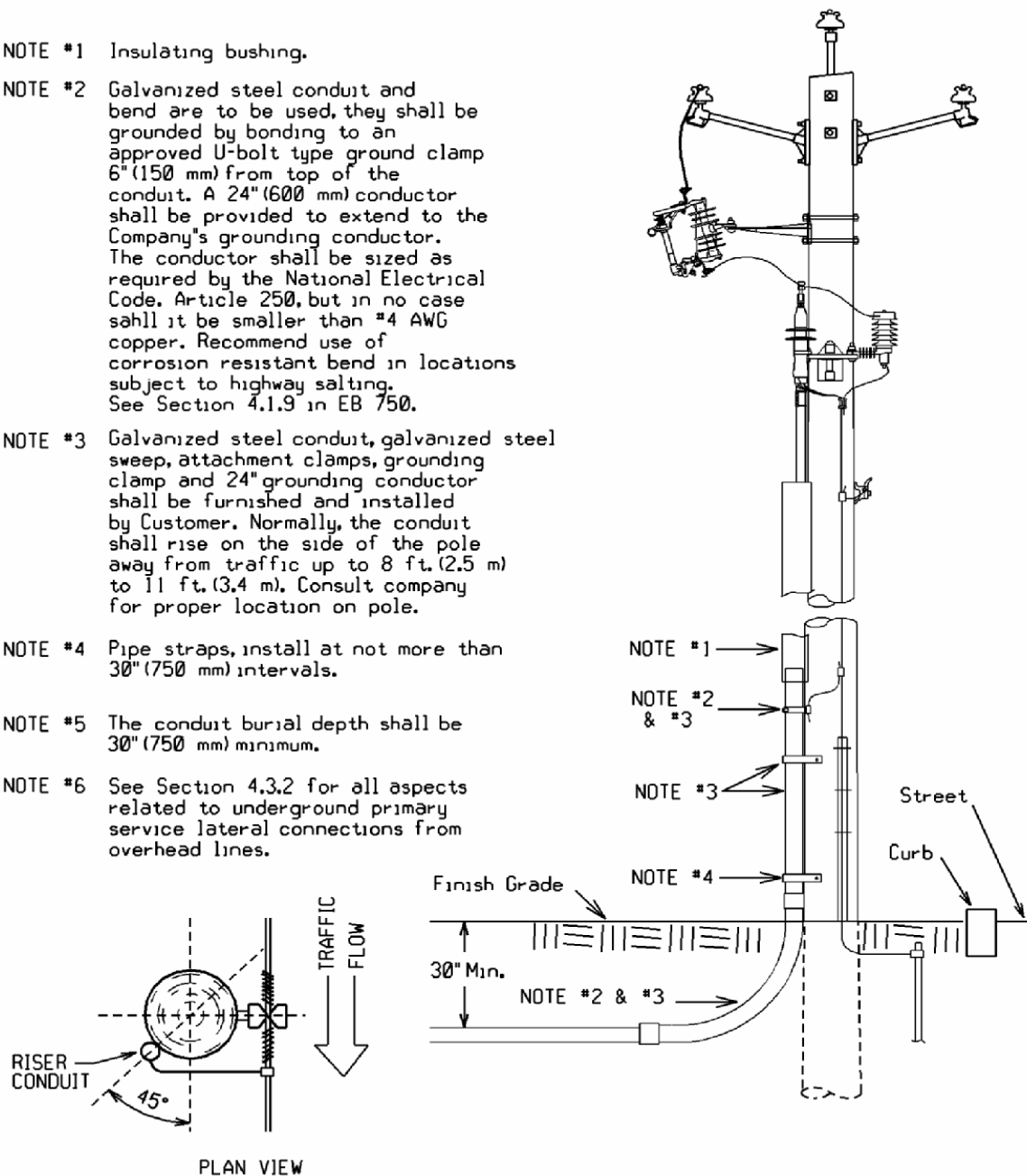
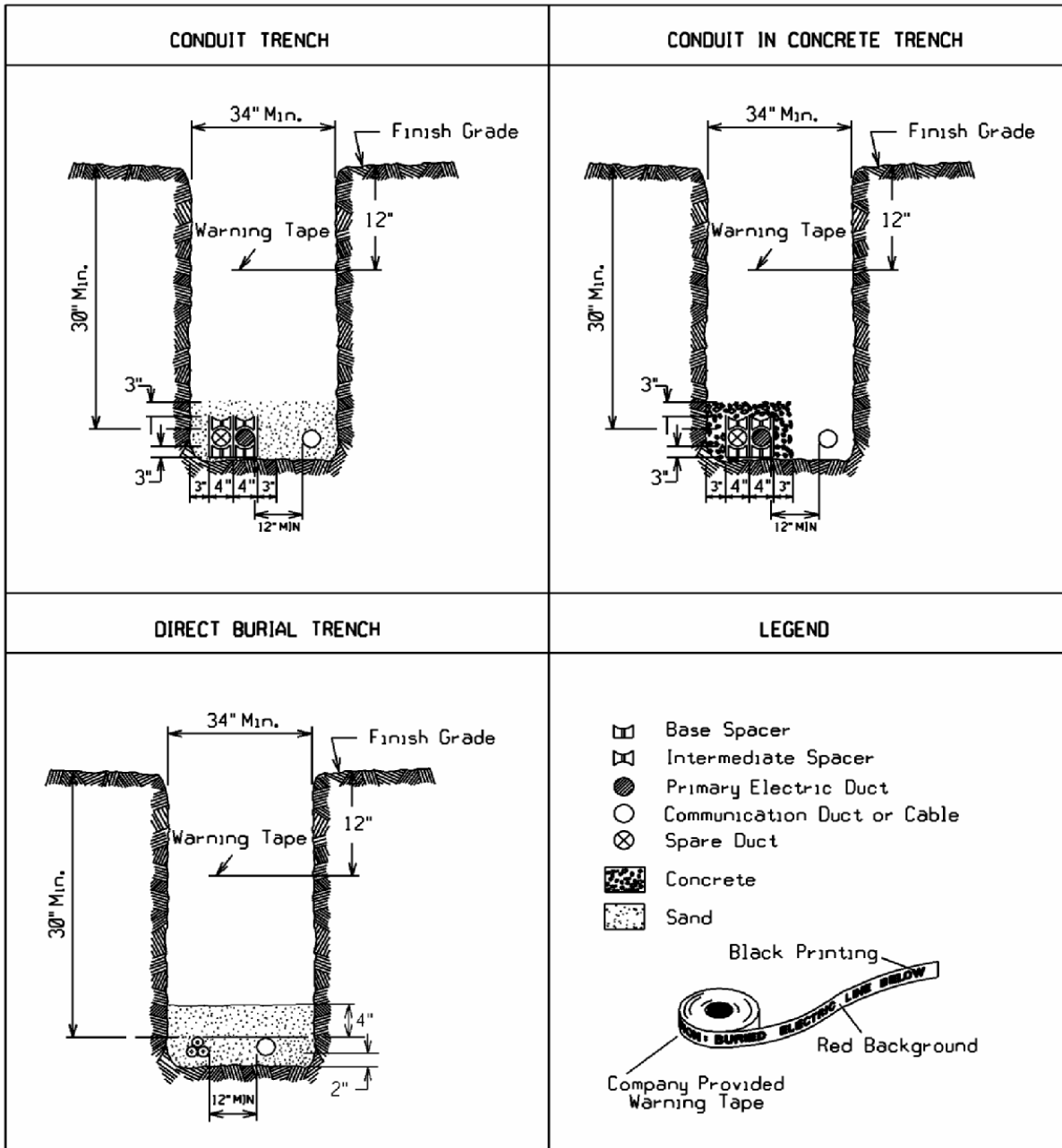

FIGURE 12

Typical Primary Riser Pole Detail



Typical Backfilling Details of Underground Primary Cable And Warning Tape Installation In Trench

FIGURE 13

TRANSFORMER FOUNDATION INSPECTION CHECKLIST

Do not pour concrete prior to inspection and approval by Company of the pad forming and reinforcement, the subgrade preparation, and the ground grid. Do not back fill after removing the forms prior to pad inspection. Every item listed below must be inspected and checked off by the Customer's qualified installer and provided to the Company.

N✓ Y✓ **PRE-INSTALLATION**

- Proposed location within 10' of paved way open to vehicular access.
- Proposed location has minimum of 10' clear space in front of transformer doors.
- Proposed location has minimum clearance to buildings, doorways, windows, ventilation ducts, fire escapes, and other combustibles according to Section 5.1 and Figure 2.
- Bollard locations are identified by Company.
- Ground grid installation and two ground rods.
- Approved pre-cast pad installed: Manufacturer _____ Model: _____

PRE-POURING (if not using pre-cast pad)

- 12" gravel and 2" sand below pad location.
- Reinforcing bars.
- Concrete forms correct height, size, orientation, opening, etc.
- Concrete forms in correct location.
- Ground grid installation and two ground rods.
- 36" radius at all 90° sweeps into pad stopping 1" above pad.
- Secondary sweeps in place and proper number.

AFTER POURING (if not using pre-cast pad and after removing forms and prior to backfilling)

- Pad correctly formed and 10" high.
- Curing time achieved according to Concrete Supplier's Specifications
- ¾" chamfer along the edges.
- Sweeps 1" above pad.

AFTER BACKFILLING

- 6" protective bollards are correctly installed.
- Pad 5" above final grade.
- Pad has 10' of clear space in front of transformer doors, is 10' from an accessible paved way and has the minimum clearance to other structures.

NOTES:

Y – Acceptable
Strikethrough requirement if not applicable.

Performed by: _____ **signature:** _____ **Date:** _____
Name (Customer's qualified installer.)

Installer Company Name: _____ **Address:** _____

Witnessed by: _____ **signature:** _____ **Date:** _____
Property Owner Name

Figure 14

TRANSFORMER SECONDARY CONNECTION CHECKLIST

Every item listed below must be inspected and checked off by the Customer's qualified installer and provided to the Company.

N ✓ Y ✓

PRE-INSTALLATION

- - Service configuration and service equipment ratings and overcurrent device meets accepted design by the Company.
- - Number of conductor sets and connectors meet Sections 4.4.1 and 4.4.3.

PRE-ENERGIZATION

- - Service cable conductors labeled for phase identification.
- - Service cable conductors continuity tested for proper phase connections to service equipment.
- - Service cable conductors megger tested for insulation integrity acceptance.
- - Company bushing current transformers installed for hot sequence metering where required.
- - Company current transformers installed in cabinet for hot sequence metering where required.
- - Secondary cable connectors torqued (*and taped, only if required by company*).
- - 3rd Party Electrical Inspection Approval Certificate provided to Company for the entire service connection according to Section 1.8 of ESB 750.
- - Ground grid resistance test provided to Company according to Section 6.3.
- - Company notified of Customer's desired energization schedule.

NOTES:

Y – Acceptable

Strikethrough requirement if not applicable.

Performed by: _____ **signature:** _____ **Date:** _____
Name (Customer's qualified installer.)

Installer Company Name: _____ **Address:** _____

Witnessed by: _____ **signature:** _____ **Date:** _____
Property Owner Name

Figure 14 (cont'd)